

PARTIAL ENGINE ASSY (2ZZ-GE) COMPONENTS

141HB-02

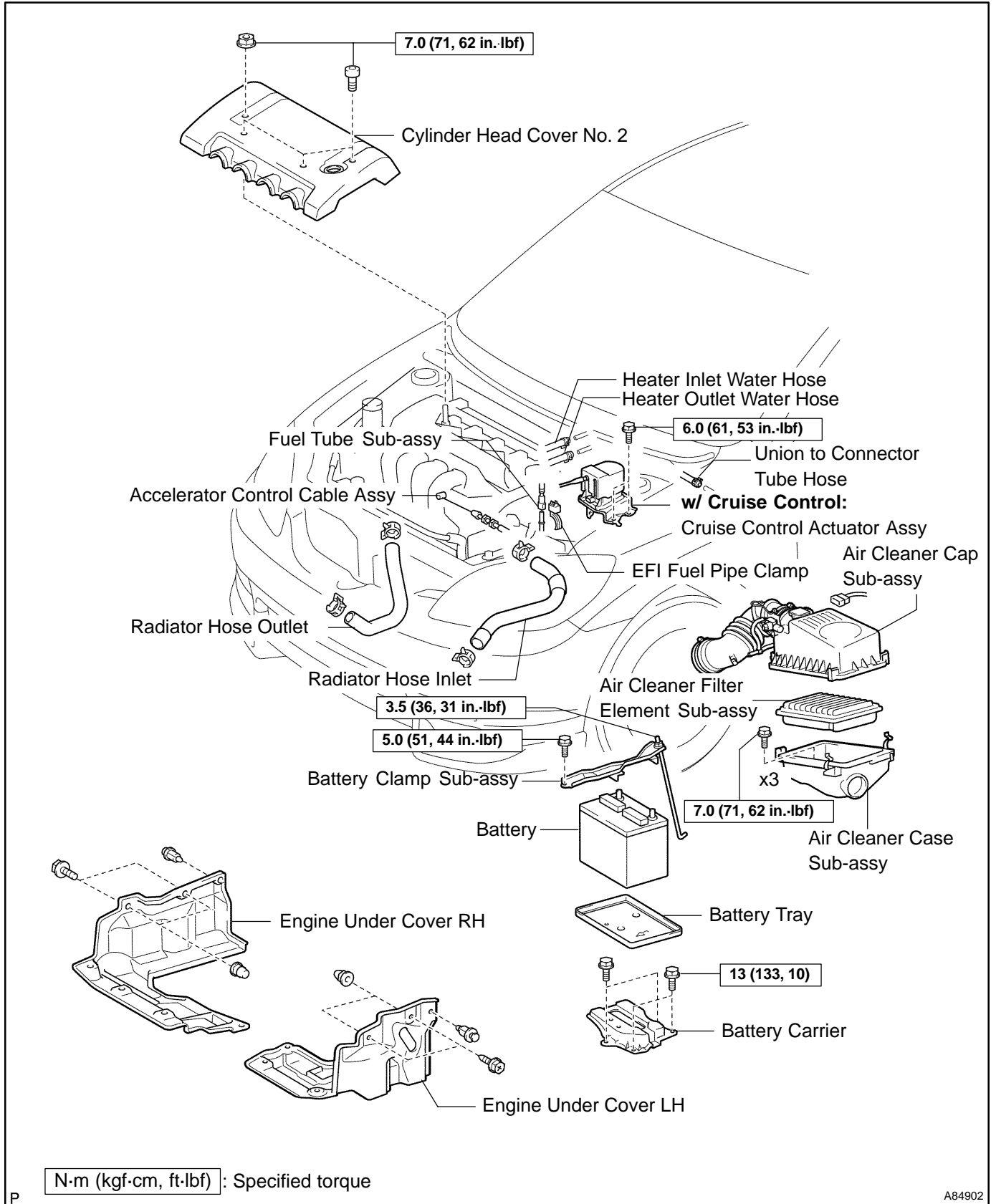

P

A84902

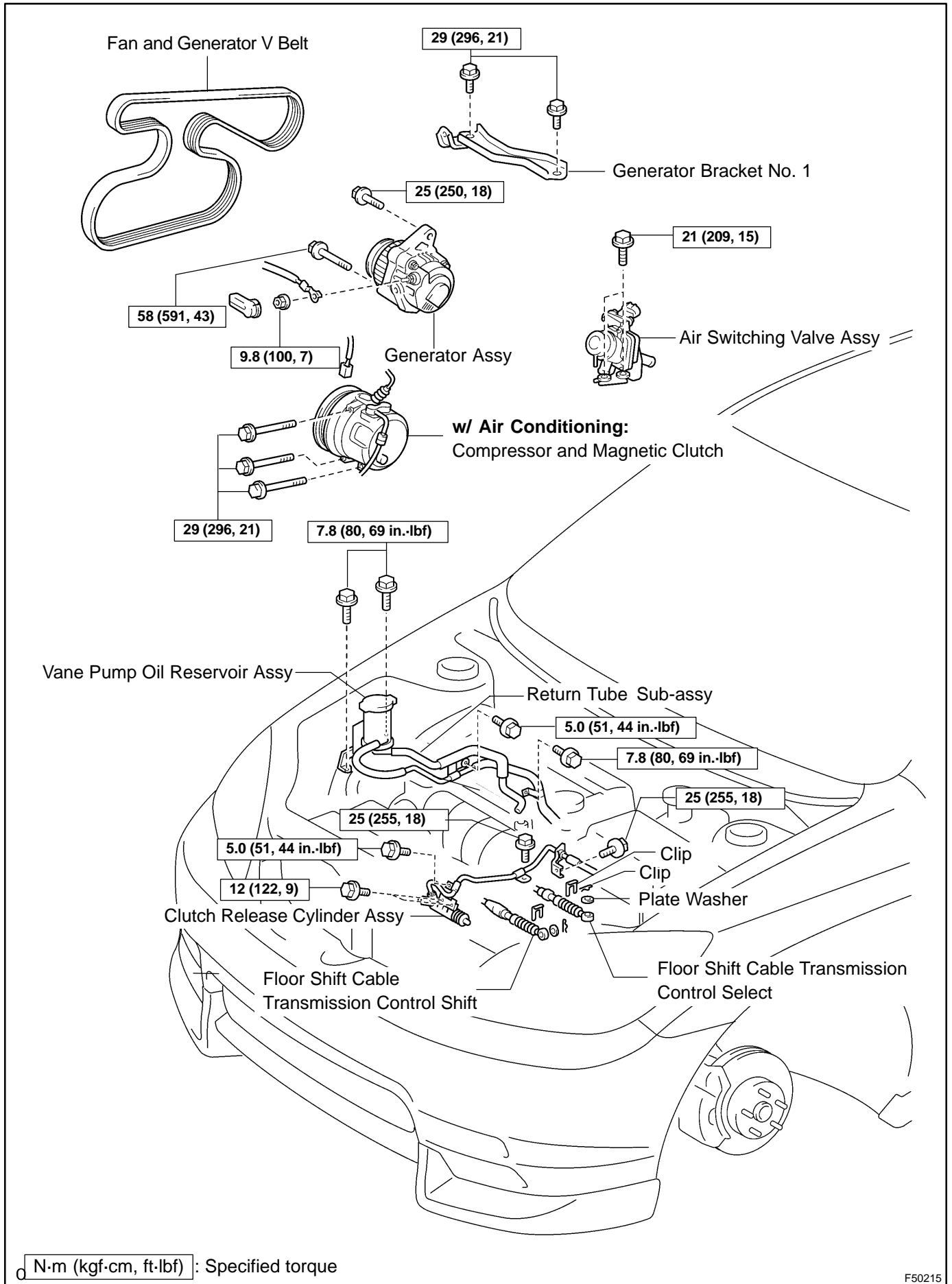

A65818
A97235

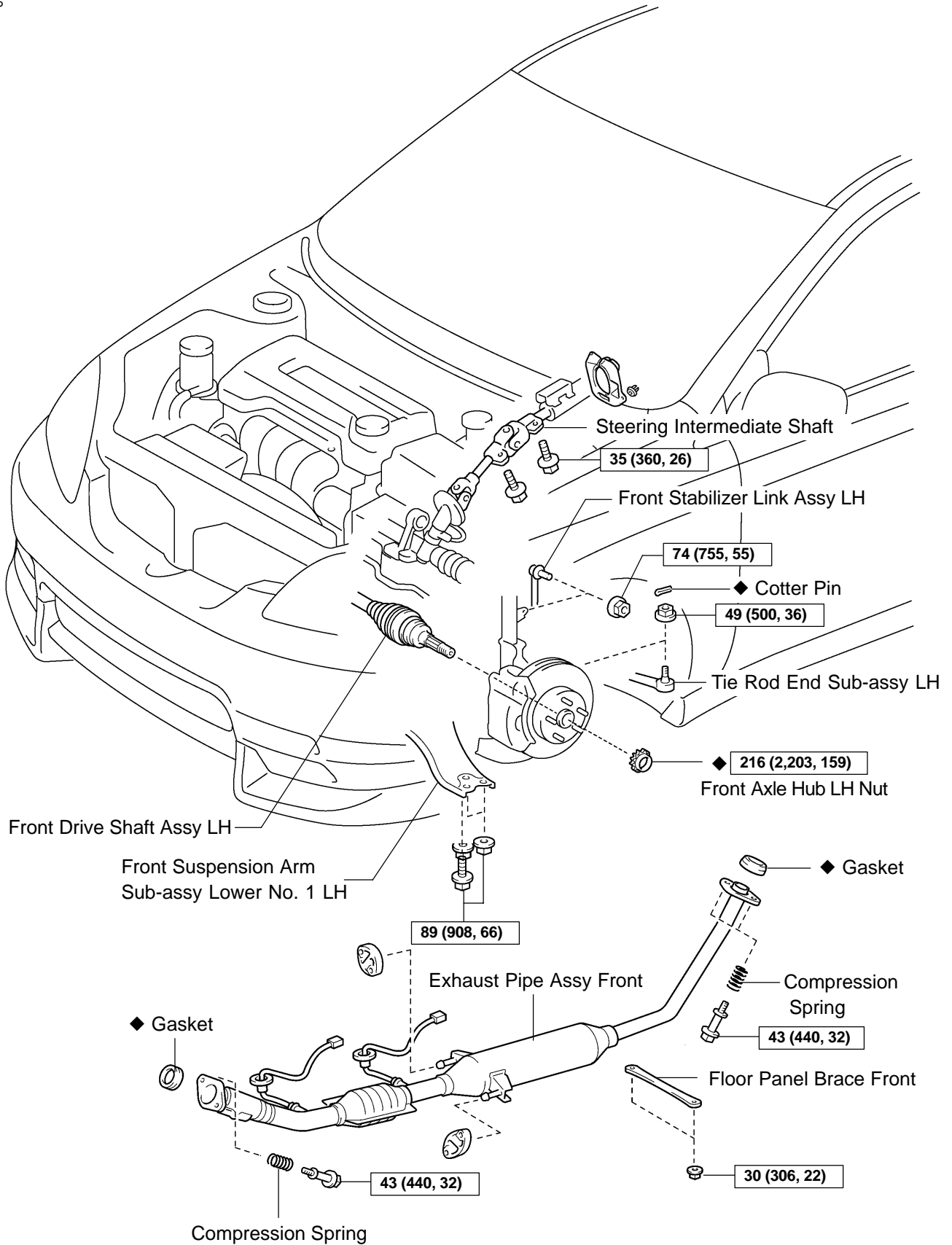

N·m (kgf·cm, ft·lbf) : Specified torque

o ◆ Non-reusable part

A99918

A84904
A97234

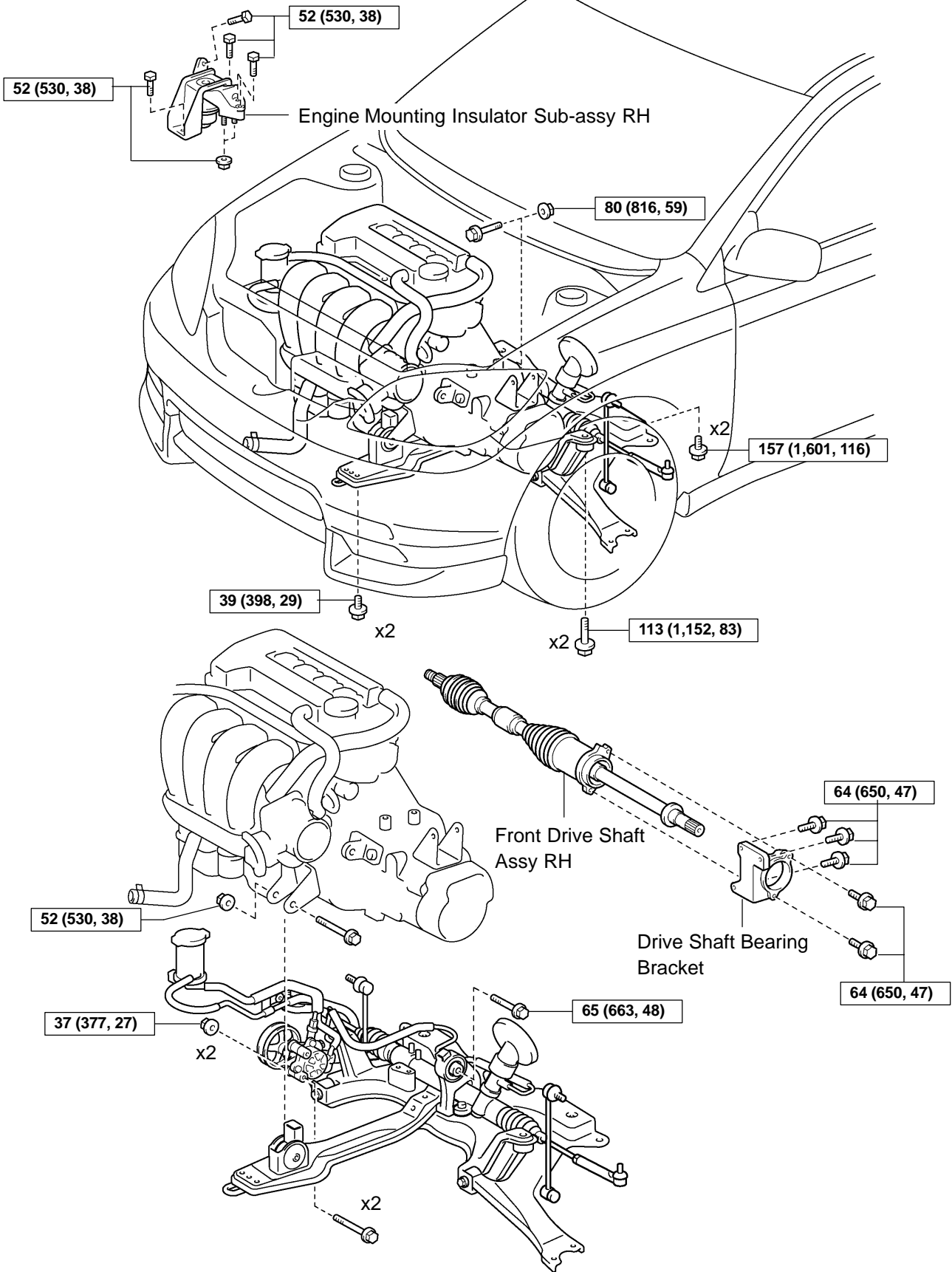

0 N·m (kgf·cm, ft·lbf) : Specified torque

G34980

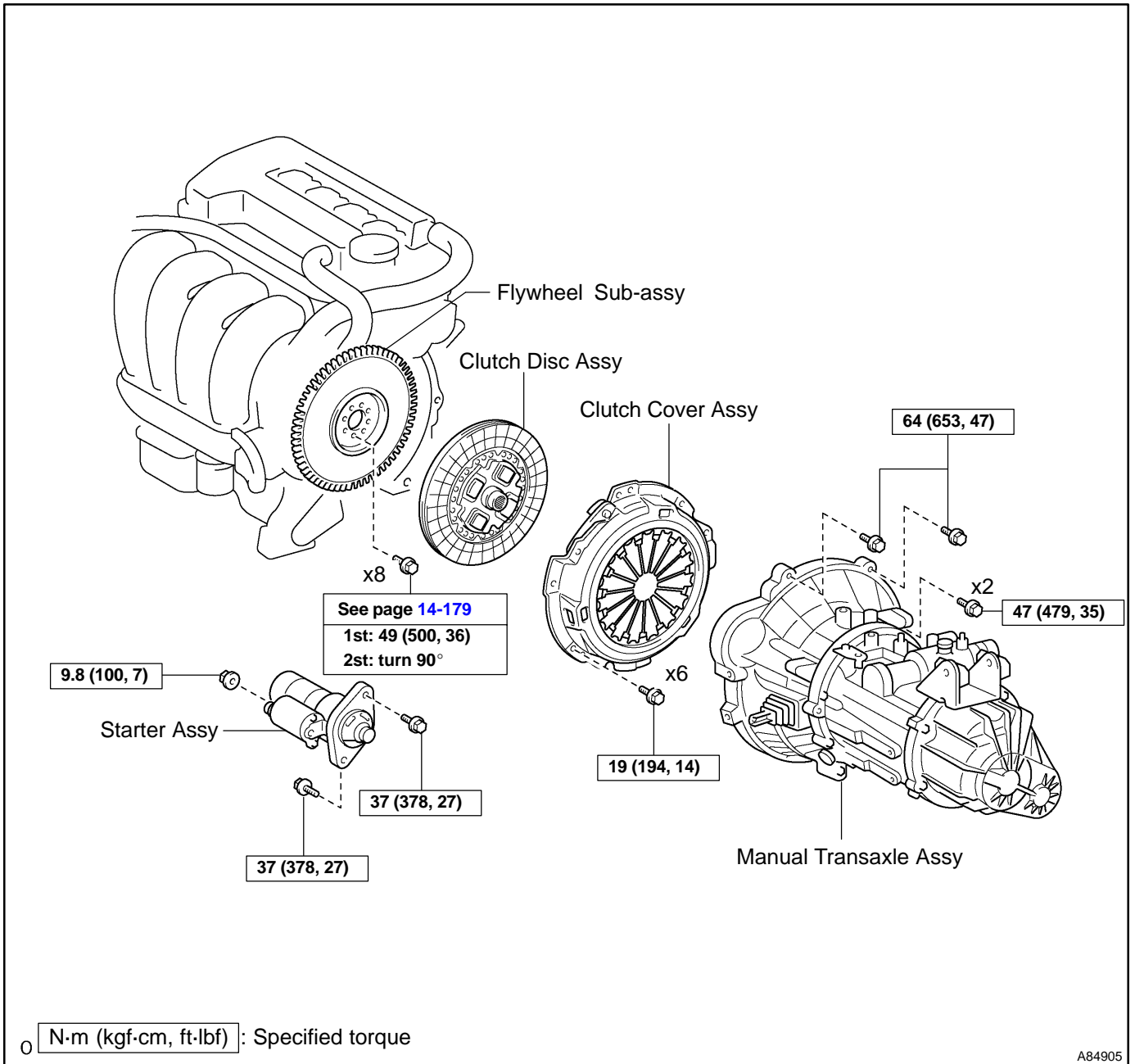

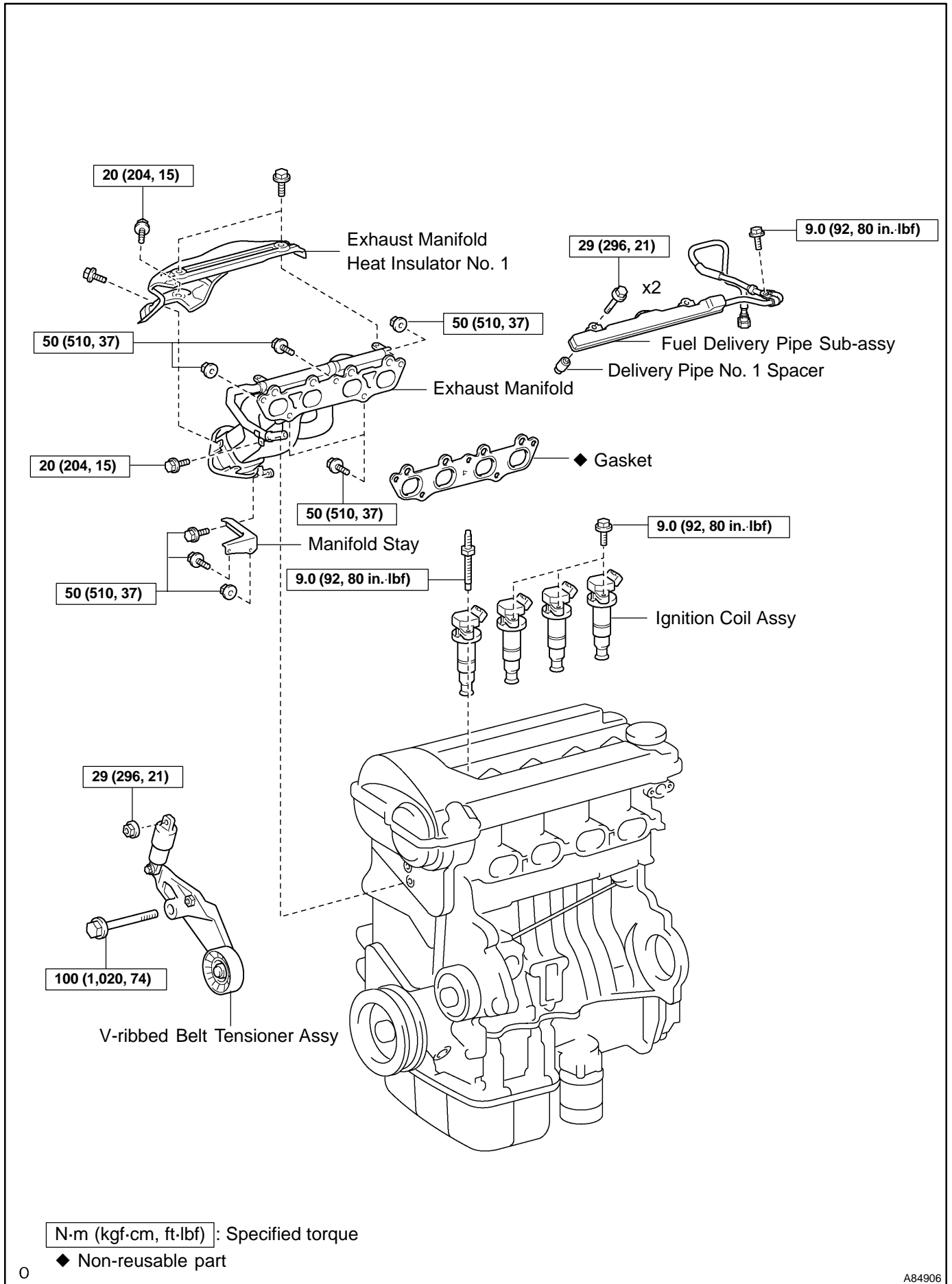

A84906

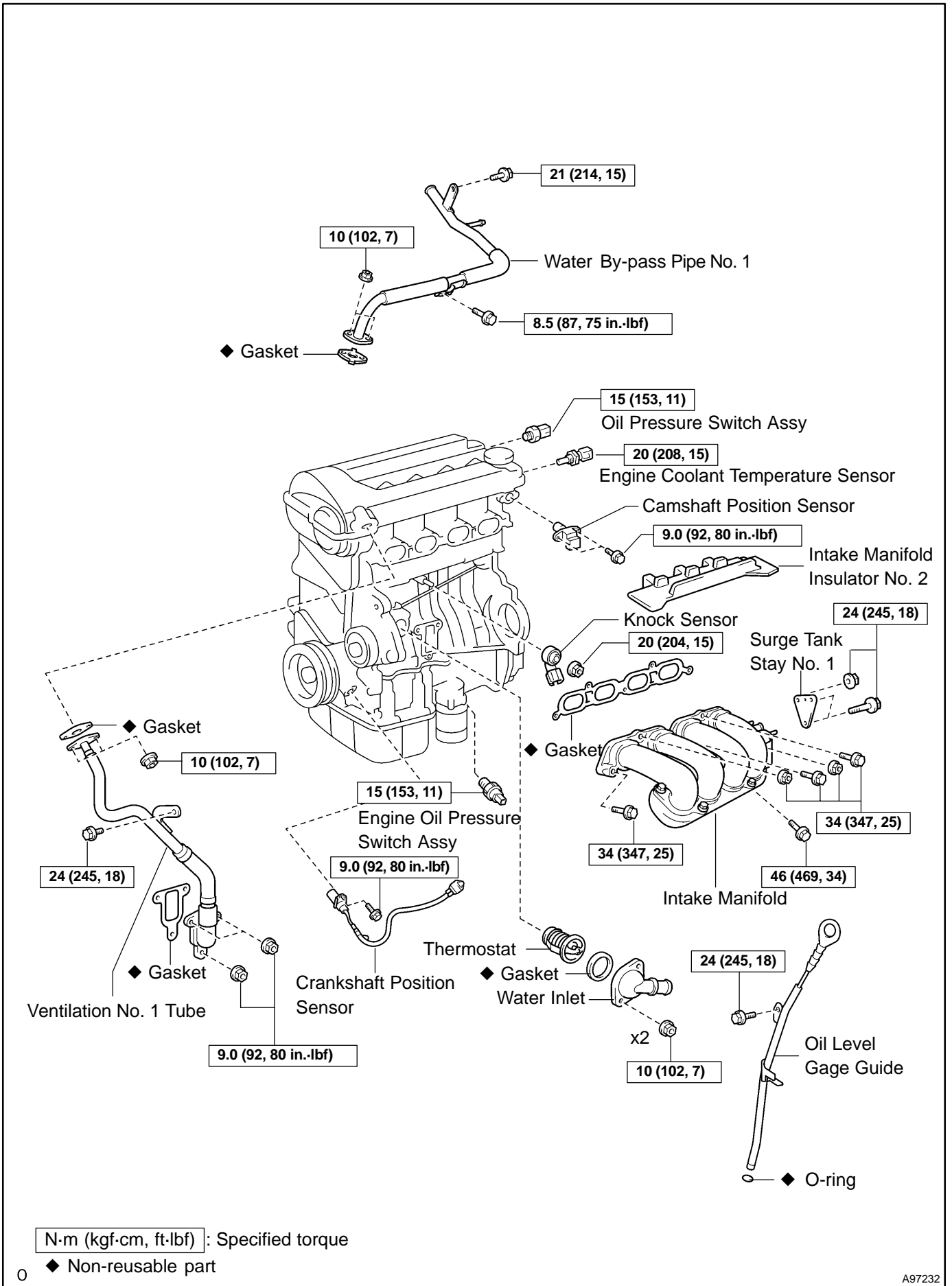

N·m (kgf·cm, ft·lbf) : Specified torque
 ◆ Non-reusable part

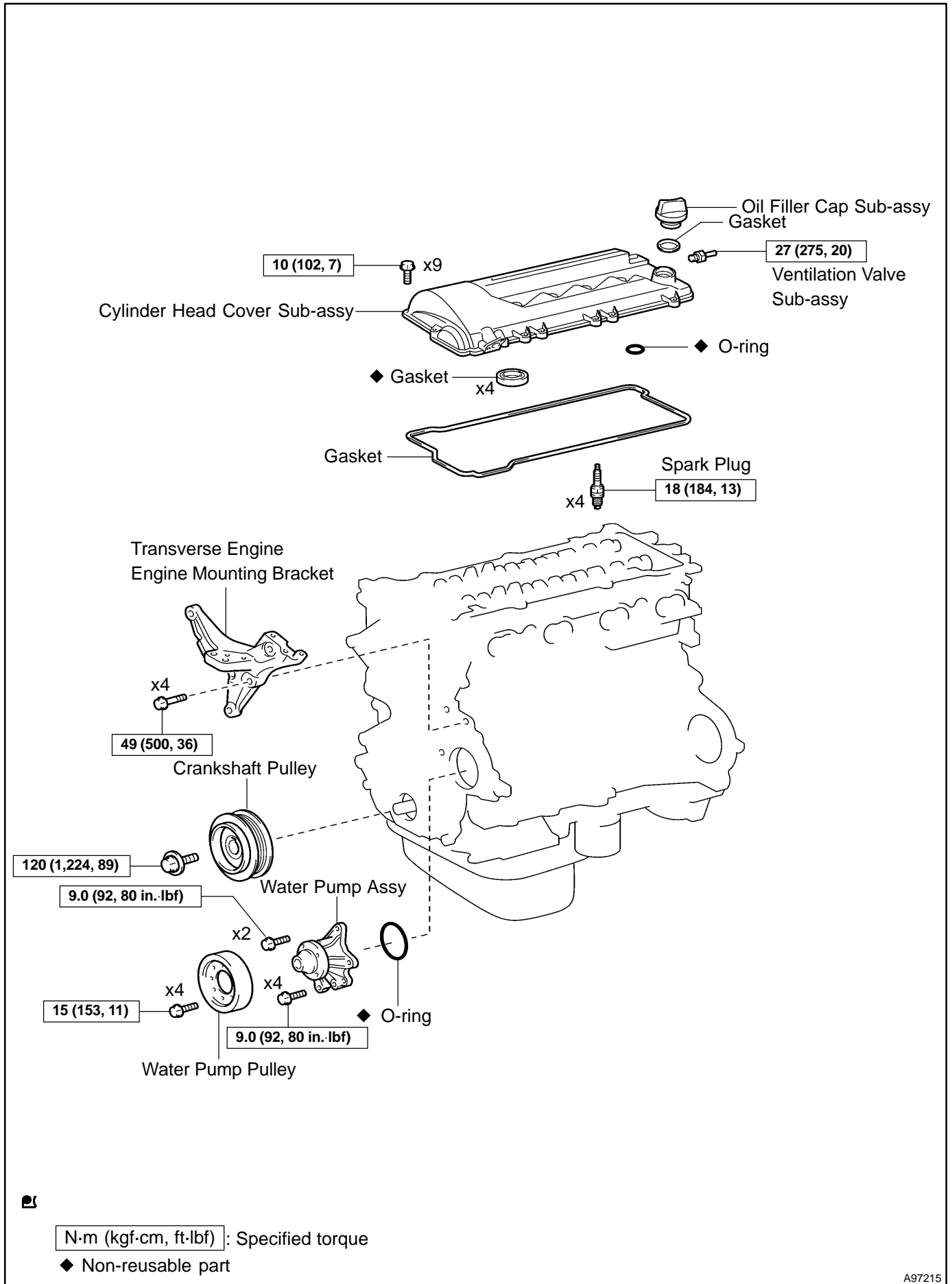

A97215

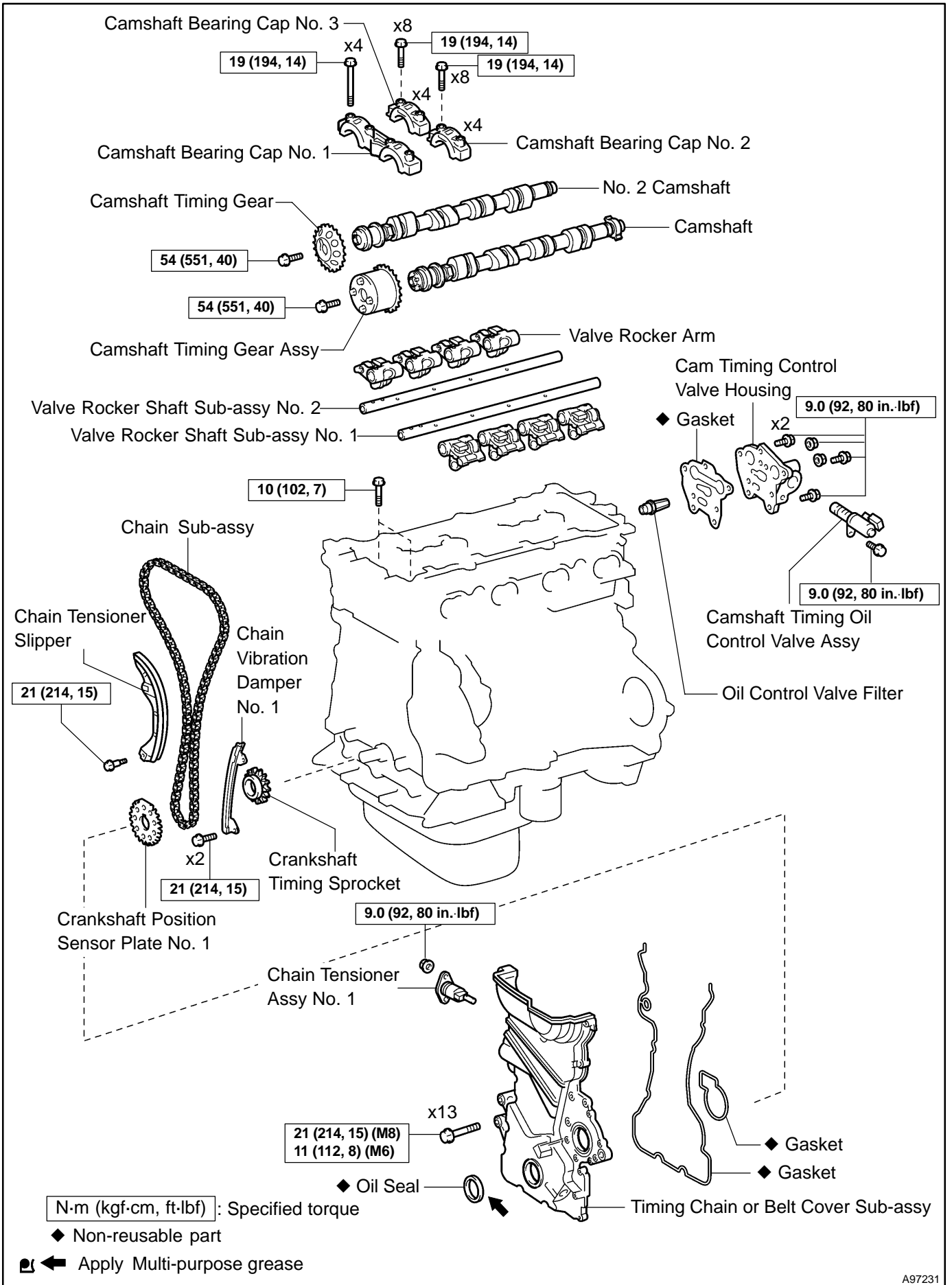

A97231

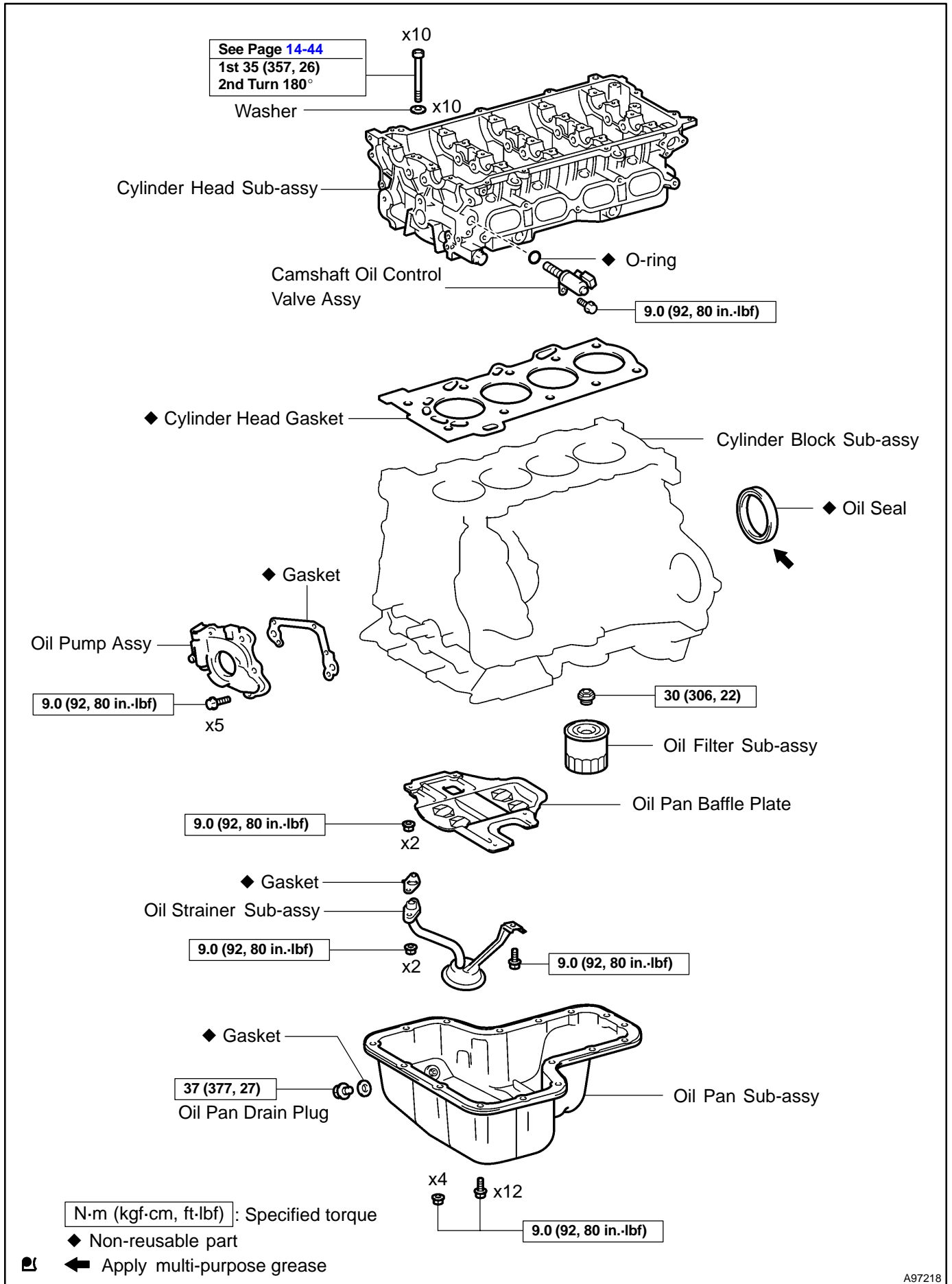

A97218