



SUPPLEMENT

EXIGE SUPERCHARGED (S/C)

| | <u>Sub-Section</u> | <u>Page</u> |
|---------------------------|--------------------|-------------|
| Concept & Overview | Exige S/C.# | 2 |
| Technical Data | Exige S/C.TD | 3 |
| Body | Exige S/C.B | 4 |
| Front Suspension | Exige S/C.C | 5 |
| Rear Suspension | Exige S/C.D | 5 |
| Engine | Exige S/C.E | 5 |
| Wheels & Tyres | Exige S/C.G | 11 |
| Brakes | Exige S/C.J | 11 |
| Cooling | Exige S/C.K | 11 |
| Maintenance & Lubrication | Exige S/C.O | 12 |
| Clutch | Exige S/C.Q | 12 |
| Miscellaneous | Exige S/C.Z | 12 |



EXIGE S/C.# - CONCEPT & OVERVIEW

In February 2005, Lotus announced the Lotus Sport Exige 240R (243 bhp) to provide discerning customers with an exclusive very high performance derivative of the Exige, to be built in a global limited edition of 50 units. The cars to be produced to customer order as post registration official factory conversions of the '05 Exige by the Lotus Sport workshops at Hethel, and available for the U.K. and certain overseas territories where regulations allow. In November 2005, Lotus Sport commenced build of a limited number of Exige Cup 240 cars in road or race specification for selected markets, and differing in detail to the 240R. Then in January 2006, an official production version of the supercharged car, Exige S, was introduced with a simplified specification.

The performance of the standard Exige is uprated by the fitment of a Magnuson supercharger belt driven from the crankshaft, feeding through an air/air chargecooler into a new plenum/intake manifold, and featuring a supercharger integral by-pass valve. The 240R engine uses a mechanical throttle and a 5th injector mounted in the intake manifold plenum, whereas the '06 M.Y. Cup cars use an electronic throttle, larger port injectors and no 5th injector, and the Exige S utilises standard injectors.

Chassis dynamics on 240R and Cup cars are uprated by the fitment of Ohlins 2-way adjustable dampers, with adjustable spring platforms for the uprated springs, and new lightweight forged 5-spoke roadwheels of slightly wider section to accommodate optional track use only slick tyres.

This supplement describes the features of the supercharged variants which differ from the standard '05 Exige model. For information on any subject matter not included here, refer to the main manual.

Lotus Sport Exige 240R

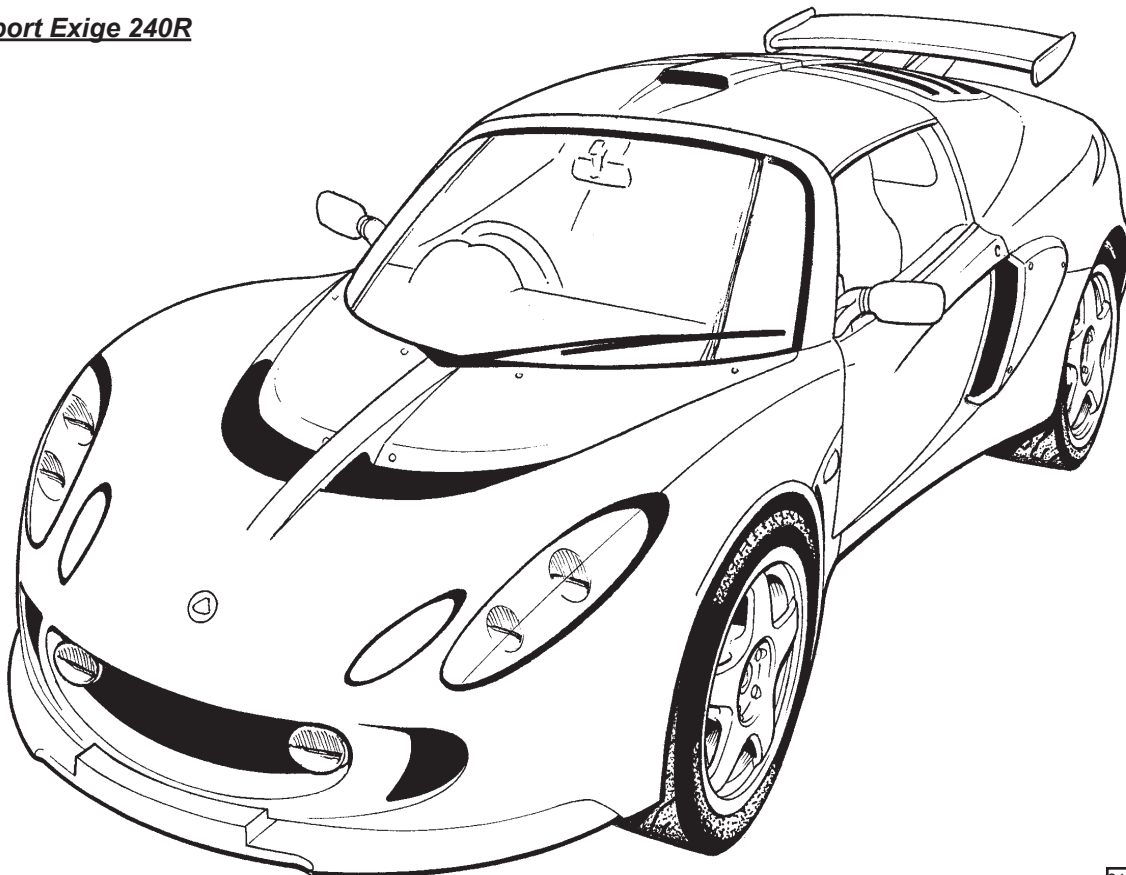

240Rint



EXIGE S/C.TD - TECHNICAL DATA

Where different to standard Exige:

Engine

Forced induction

Magnuson MP62 supercharger with integral by-pass valve.

Air/air chargecooler.

Maximum boost pressure

0.5 bar (7 psi)

Max. power - 240R & Cup
- Exige S

181 kW (243 bhp; 247 PS) @ 8000rpm

162.5 kW (218 bhp; 221 PS) @ 7800rpm

Max. torque - 240R & Cup
- Exige S

236 Nm (174 lbf.ft; 24 kgf.m) @ 7000rpm

215 Nm (158.6 lbf.ft; 22 kgf.m) @

5500rpm

Power to weight ratio - 240R & Cup

195 kW/t (261 hp/t; 266 PS/t)

Specific power output - 240R & Cup

100.78 kW/l (136.97 hp/l; 137.4 PS/l)

Lubrication system supplement - 240R & Cup

Accusump oil storage reservoir

Oil cooling

Twin front mounted oil coolers

Wheels & Tyres

Wheels - type - 240R

Lightweight forged alloy 5-spoke, satin black or high power silver

- size - front - 240R

7J x 16

- rear - 240R

8J x 17

Suspension

Ride height, mid laden, front/rear - 240R & Cup

120/120 (2 x 75 kg pass., ½ tank fuel)

Spring rate - front - 240R & Cup

325 lb/in

- rear - 240R & Cup

425 lb/in

Front anti-roll bar - 240R & Cup

5-position adjustable

Dampers - 240R & Cup

Ohlins gas pressurised with remote reservoirs, 2-way damper adjustment, adjustable spring top platforms.



EXIGE S/C.B - BODY

Exterior

All 50 of the 240R cars are finished in high metallic content paint in either Sport Yellow or Sport Black, reflecting the brand colour scheme of Lotus Sport. Yellow cars are complemented by black roadwheels, and black cars with high power silver wheels.

A Lotus Sport 240R decal is applied to the RH side of the rear transom.

Paint Codes:

Sport Yellow: Lotus code B112 Du Pont code X3454

Sport Black: Lotus code B111 Du Pont code X3453

240 Cup and Exige S models were offered in the complete range of colours with the front splitter, side intake scoops and the rear aerofoil (excluding support struts) finished in body colour rather than satin black. Exige S cars feature an 'Exige S' decal on the rear transom, and an 'S' decal on each front quarter panel. Both decals available in grey or silver dependent on body colour.

The chargecooler air intake scoop on the roof of Exige S models is fitted with an enlargement funnel mouth (without grille) for increased airflow and enhanced chargecooler efficiency.

Interior

Each Lotus Sport Exige 240R is individually numbered from 001 to 050, and identified by a Lotus Sport build plate styled after those used by Team Lotus for the Formula One cars. The plate is riveted to the chassis main side rail on the passenger side, and is engraved with the unique Limited Edition number.

The 240R features black leather sports seats embroidered on the head restraints with Exige branding in yellow, with further Lotus Sport yellow highlights on the seat sides, door trim inserts, gear lever gaiter and parking brake lever gaiter. Cup cars use black leather/suede/carbon effect trim with '06 M.Y. Probax sports seats.

240R and Cup cars are fitted with four point seat belt harnesses, with the shoulder straps anchored to a seat belt mounting frame (roll hoop) cross bar. The roll hoop and back stays on these cars are manufactured in T45 steel to allow easy conversion to U.K. motorsport MSA approval by the addition of an 'A' frame and diagonal brace.

All 240Rs are equipped with air conditioning, but is optional on other models.



EXIGE S/C.C - FRONT SUSPENSION - 240R & CUP

Stiffened road springs front and rear are fitted on new Ohlins dampers featuring remote gas reservoirs, adjustable spring platforms and separate adjustments for compression and rebound damping. The spring platforms allow for lowering of the car to 120/120mm mid-laden ride height for track use, and the 22 compression and 60 rebound damper settings allow the characteristics to be fine tuned to individual requirements. The gas reservoir is mounted on the inboard crossbrace of the lower wishbone, and is connected to the damper body by a steel braided hose.

Compression (bump) damping is adjusted by turning the knob on the end of the gas reservoir canister: Turn clockwise to increase damping, and counterclockwise to decrease. Recommended settings are as follows:

Road use: 11 clicks from full hard

Track use: 11 clicks from full hard

Rebound damping is adjusted via a ribbed collar below the bottom spring seat: Turn clockwise (as viewed from below) to increase damping, and counterclockwise to decrease. Recommended settings are as follows:

Road use: 8 clicks from full hard

Track use: 8 clicks from full hard

The motorsport stiffened and 5-position adjustable front anti-roll bar provides further opportunity for fine tuning. To stiffen the bar, use a more forward hole, and to soften, use a more rearward hole. Recommended setting:

Road use: Central hole

Track use: Central hole

Suspension geometry is unchanged - refer to Section TDQ.

EXIGE S/C.D - REAR SUSPENSION - 240R & CUP

Stiffened road springs front and rear are fitted on new Ohlins dampers featuring remote gas reservoirs, adjustable spring platforms and separate adjustments for compression and rebound damping. The spring platforms allow for lowering of the car to 120/120mm mid-laden ride height for track use, and the 22 compression and 60 rebound damper settings allow the characteristics to be fine tuned to individual requirements. On 240R models the gas reservoirs are mounted on the roll over bar backstays, and on Cup cars, on the toe-links. Each reservoir is connected to its damper body by a steel braided hose.

Compression (bump) damping is adjusted by turning the knob on the end of the gas reservoir canister: Turn clockwise to increase damping, and counterclockwise to decrease. Recommended settings are as follows:

Road use: 15 clicks from full hard

Track use: 10 clicks from full hard

Rebound damping is adjusted via a ribbed collar below the bottom spring seat: Turn clockwise (as viewed from below) to increase damping, and counterclockwise to decrease. Recommended settings are as follows:

Road use: 15 clicks from full hard

Track use: 12 clicks from full hard

Suspension geometry is unchanged - refer to Section TDQ. The Track Use Chassis Rear Brace Kit is fitted as detailed in sub-section DH.5.

EXIGE S/C.E - ENGINE

The 1.8 litre 2ZZ-GE engine with VVTL-i (Variable Valve Timing and Lift - intelligent) of the standard Exige is fitted with a low pressure Roots type Magnuson MP62 supercharger to provide up to 0.5 bar (7 psi) of boost pressure. The supercharger is mounted on the left hand side of the block and driven by a lengthened version of the multirib auxiliary belt. The unit is self contained and features helix twisted rotors to minimise output pressure variations, and maintenance free gearing and bearings, requiring no externally sourced lubrication. An integral bypass valve under ECU control, operates to recirculate air from the compressor outlet back to the inlet under conditions of idle and part throttle to the benefit of economy and quiet operation.

The supercharger is hung off the new intake manifold by two bolts in conjunction with eccentric sleeves in order to ensure stress free alignment. An alloy bracket supports the nose of the unit to the RH engine mounting plinth, and a tubular strut braces the intake end of the unit to the clutch slave cylinder mounting point.

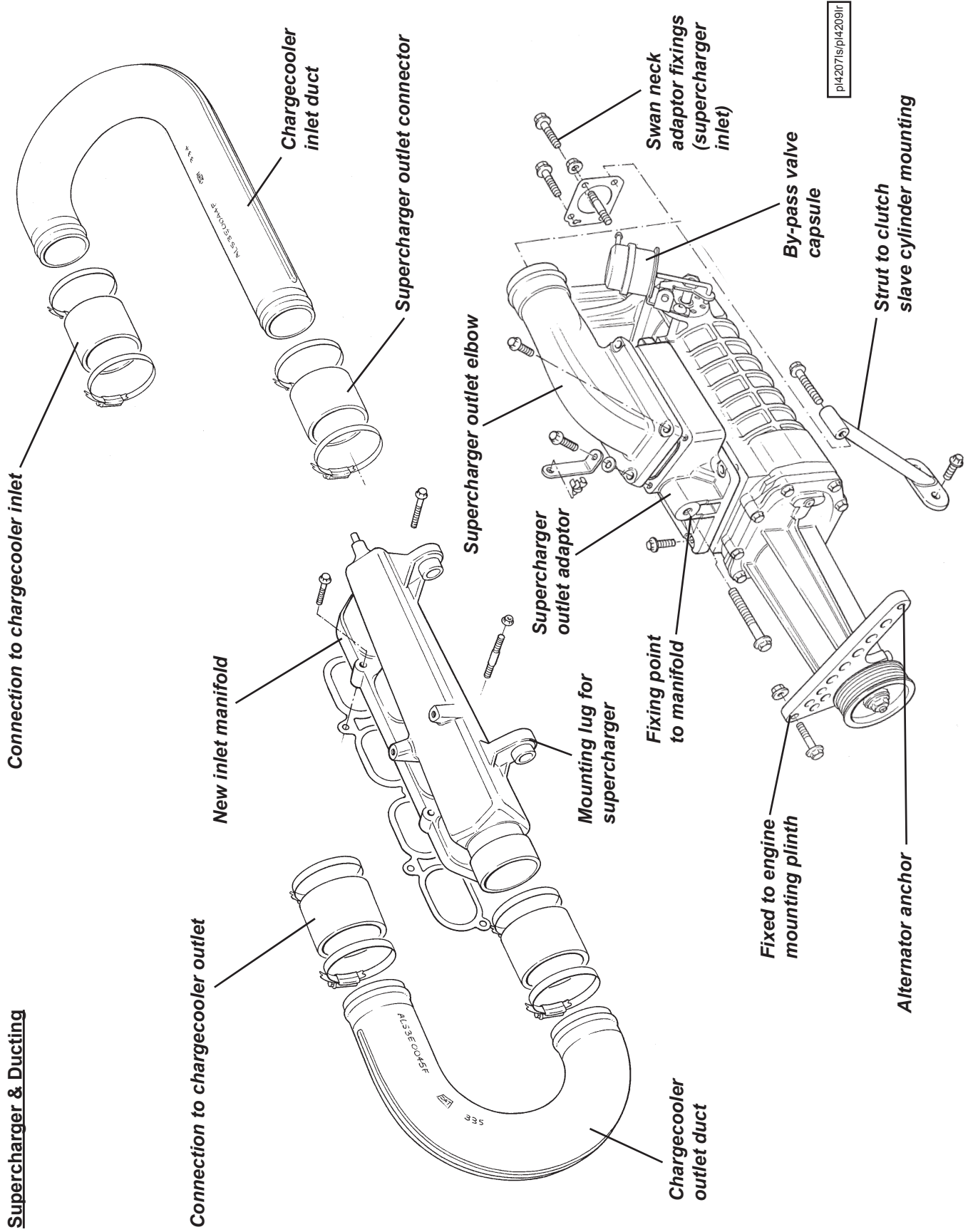

pl42071s/pl42091r

Supercharger & Ducting

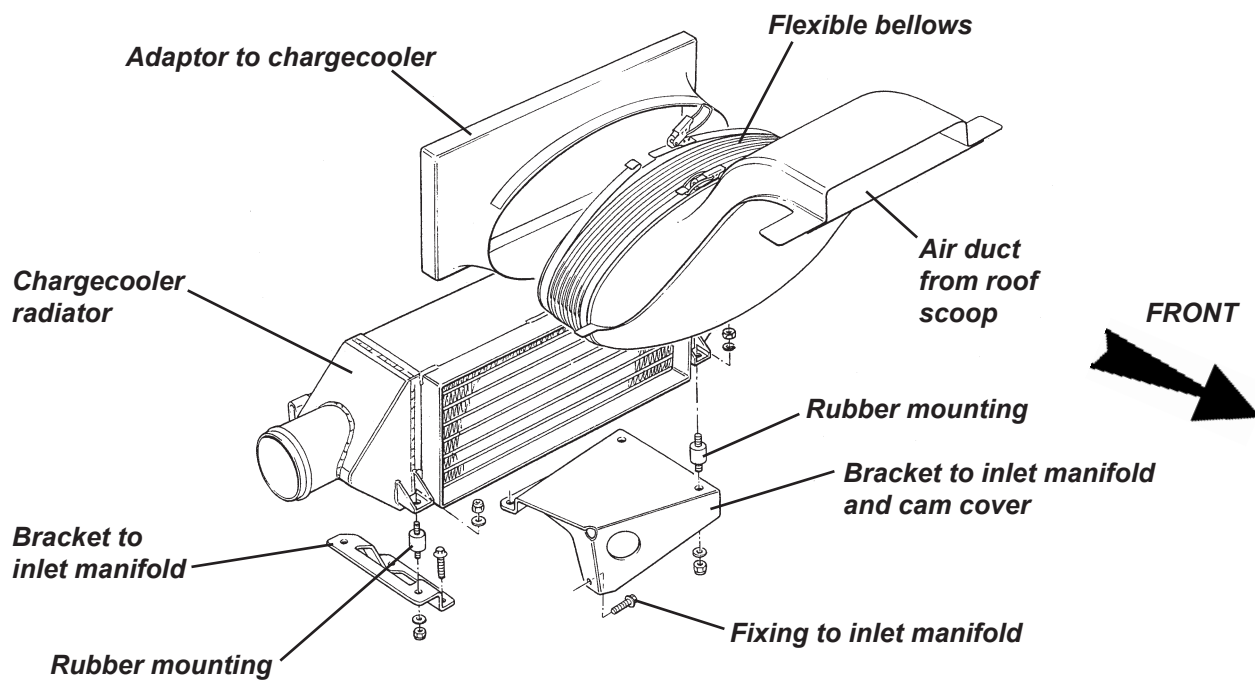
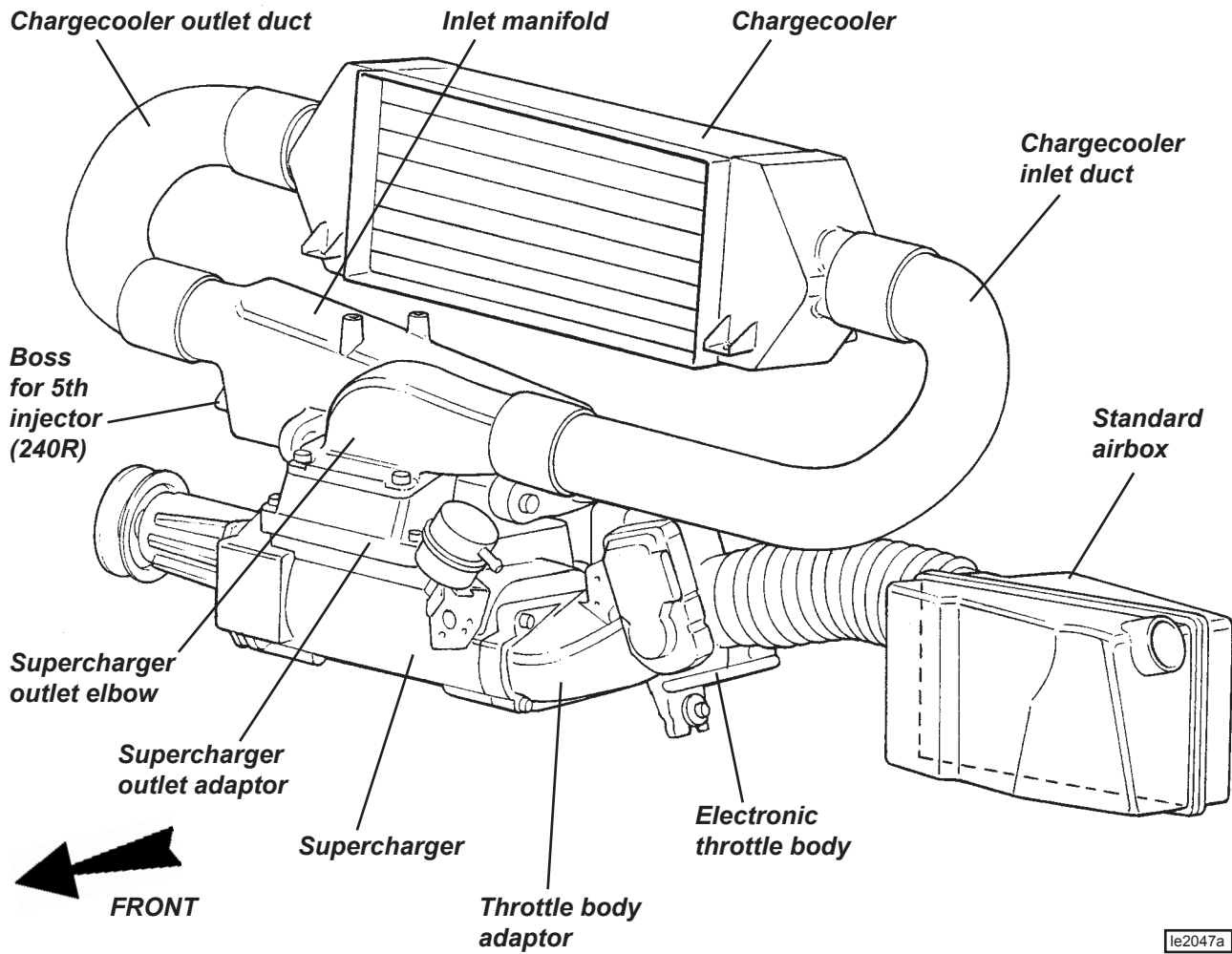



Air is drawn from the standard air cleaner through the throttle body and adaptor and into the supercharger axial intake port. From the outlet port on the compressor top surface, the air is directed through a 'U' bend duct to the LH end of an air/air chargecooler rubber mounted above the engine, where airflow gathered from the roof duct is used to cool the compressed intake charge. The chargecooler uses four rubber bobbins attached to two mounting brackets themselves secured to the inlet manifold and cam cover. A charge air temperature sensor is mounted in the outlet tank of the chargecooler. The cooled air exiting from the RH end of the chargecooler flows via another 'U' bend duct into a cast alloy intake plenum/manifold. The whole intake tract has been kept as short as possible, and uses large diameter ducting and generously radiused bends to optimise airflow and efficiency to the particular benefit of throttle response and fuel economy.

A re-shaped breather pipe is used to connect the crankcase breather spigot to the cam cover and circumnavigate the supercharger.

On the 240R and Cup cars, a stainless steel 'level one' sports exhaust muffler (LOTAC05334) is fitted to provide an acoustic enhancement and features enlarged, slash cut tailpipes and a near 20% weight saving over the standard system. Exige S models use a stainless muffler with a single, oval shaped, tailpipe design.

240R models use 4 standard port fuel injectors together with an additional 5th injector mounted in the intake end of the inlet manifold. Cup cars use 4 special high-flow port injectors, and Exige S cars retain standard injectors. The Lotus engine management system is reprogrammed to suit each engine specification and incorporates additional functions to control the fifth injector (240R) and supercharger by-pass valve. The boost characteristics have allowed the switching point from low to high lift cam profile to be reduced from 6,000 to 4,000 rpm (at normal running temperature). 240R models use a mechanical cable operated throttle body, whereas the Cup and Exige S cars use '06 model electronic throttle. Twin front mounted oil/air coolers are fitted to all supercharged Exige.

Accusump - 240R & Cup 240

To provide protection against the possibility of oil starvation caused by the extreme g-forces possible with track use on slick tyres, the 240R and Cup cars are fitted with an Accusump oil storage system.

A 2-litre Accusump reservoir is mounted in the rear luggage compartment, plumbed into the LH oil cooler return hose at the front of the engine bay, with the connecting hose routed over the RH rear wheelarch. The device comprises an alloy cylinder divided by a sliding piston, one side of which is connected to the engine oil supply, with the other containing pressurised air. With the engine running, the cylinder is charged with oil provided by the engine oil pump, but if the pressure should drop for a short period due to oil pump pick up pipe exposure during extreme braking or cornering events, the accumulator air pressure forces the stored oil into the engine lubrication system to maintain continuity of oil supply until normal conditions are resumed.

A one-way valve at the oil cooler connection of the 'T'- piece ensures that the oil discharged from the Accusump is directed into the oil pump and not the cooler. An Electric Pressure Control (EPC) valve fitted at the connection to the Accusump cylinder, allows cylinder charging when oil pressure is above 35 - 40 psi, and cylinder discharging at engine oil pressures below 35 - 40 psi. The EPC is also linked to the ignition switch such that with the ignition switched on the valve is open to allow oil flow, and with ignition off the valve is closed to retain oil within the reservoir.

Normal Operation

When the ignition is turned on, the EPC valve on the Accusump is opened, allowing the pressurised oil stored in the reservoir to flow out into the engine and prime the oil galleries and bearings ready for start up. When the reservoir has been emptied, the pressure gauge on the end of the reservoir will indicate the pre-charge pressure which should be 7 - 15 psi.

When the engine is started, engine oil pressure will force the reservoir piston back, such that the reservoir air pressure gauge will indicate engine oil pressure, with the quantity of stored oil dependent on this pressure at any one time. With cold oil, 80 psi may be seen, but idling at normal running temperature should produce around 30 - 40 psi.

When the engine is stopped, the EPC valve closes and a quantity of oil pertaining to that oil pressure will be retained in the Accusump, ready for re-starting.

Routine Checks

Be aware that the indicated oil level on the dipstick will depend on the amount of oil stored in the Accusump, which itself is dependent on the both the Accusump pre-charge air pressure and the engine oil pressure when the ignition was switched off.

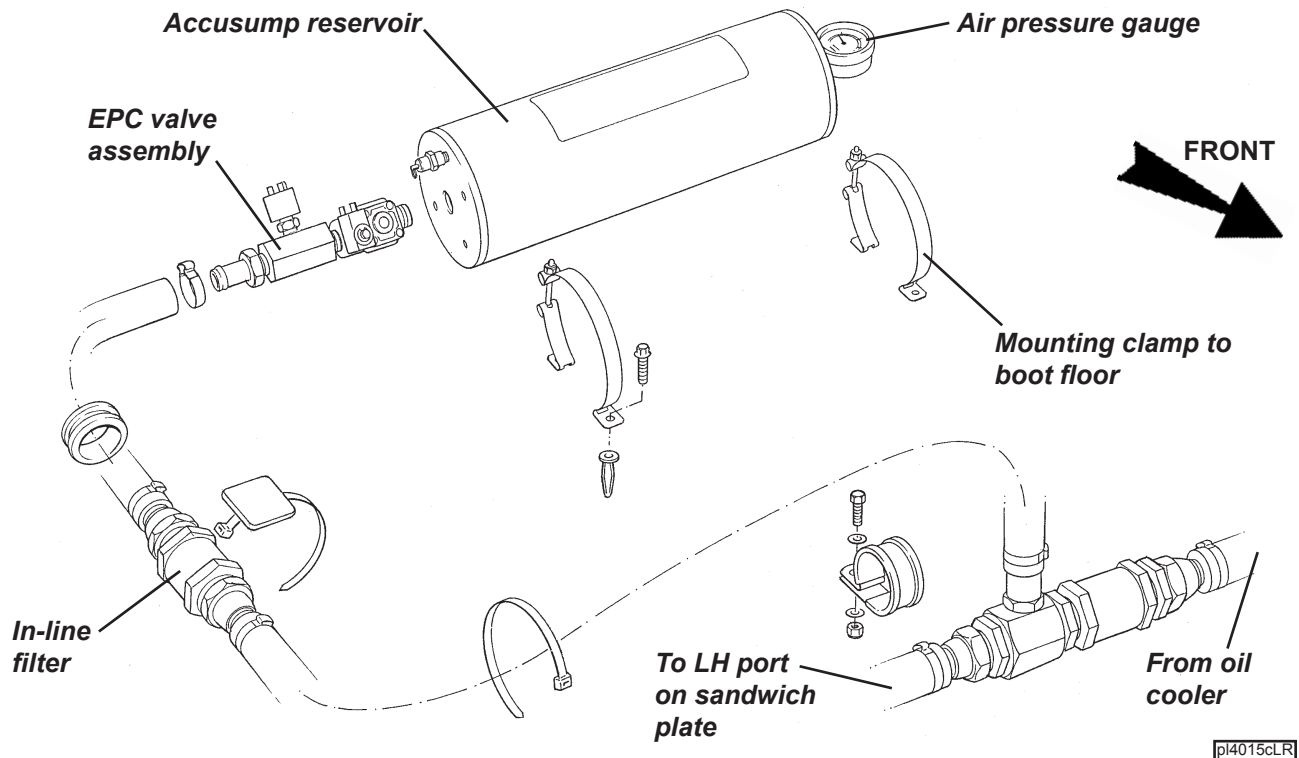

Before checking the oil level, the Accusump pre-charge pressure should first be checked; turn on the ignition to open the EPC valve and allow the stored oil to be discharged from the Accusump. The pressure gauge reading will drop during this discharge, but should then register 7 - 15 psi representing the pre-charge. If necessary, adjust the air pressure using tyre inflator equipment on the Schraeder valve adjacent to the gauge and set to 15 psi.

The oil level should now be above the top mark on the dipstick. To check for correct oil level, the engine should be started to charge the Accusump, and run to normal operating temperature until the Accusump pressure gauge registers 40 psi. If the engine is already hot, idle oil pressure may not be sufficient to open the Accusump valve, and the pressure gauge will continue to show 15 psi pre-charge. Increase engine rpm to open the valve. With the gauge showing 40 psi, turn off the engine. The EPC valve will then close and trap the normal hot idle quantity of oil in the Accusump cylinder. After a suitable oil drainback pause, the sump oil level may then be inspected on the dipstick, and the level corrected to the top mark. It is important to maintain oil at this level to accommodate the oil transfer into the Accusump at pressures greater than 40 psi. Be aware that checking the oil level under any conditions other than 15 psi pre-charge and 40 psi oil pressure will produce inconsistent results.

Oil Changing

Before draining the sump, the ignition should first be switched on to open the EPC valve and allow the Accusump to discharge the stored oil into the sump. Check that a pressure of 7 - 15 psi remains in the Accusump at the end of this process, and if necessary top up the pressure using tyre inflating equipment on the Schraeder valve next to the gauge and set to 15 psi.

The oil can then be drained in the usual way, with the quantity contained in the oil cooler lines disregarded for the purposes of routine maintenance. If an engine failure has occurred, with possible debris contamination of oil hoses and coolers, it is recommended to replace both oil coolers, and to replace or thoroughly flush the feed and return hoses. At each service interval the in-line filter gauze in the hose between the Accusump and 'T'- piece, and located in the RH rear wheelarch, should be renewed.

After renewing and pre-filling the engine oil filter, refill the sump to about 10mm above the top mark on the dipstick. Start the engine and allow to idle. Do NOT rev the engine or drive the car. The Accusump will take up to 2 litres of oil from the sump to store within the cylinder. Continue to idle the engine until the Accusump pressure gauge drops to 40 psi (as the oil warms) and then switch off the engine. Top up the oil to the top mark on the dipstick.



Supercharger Remove/Refit

To remove:

1. Remove the chargecooler together with inlet and outlet 'U' shaped ducts.
2. Remove the throttle body and vacuum/breather hose plumbing.
3. Using a 6-point socket, relieve auxiliary belt tension and remove the auxiliary belt. Remove the alternator top mounting bolt, slacken the lower, and swing down the alternator. Release the dipstick tube from the supercharger.
4. Using a strap wrench, remove the supercharger pulley retaining nut, and slide off the pulley.
5. Remove the support strut between the throttle body adaptor and the clutch slave cylinder. Slacken the pinch bolt securing the supercharger to the nose bracket. Remove the two bolts supporting the supercharger to the inlet manifold and withdraw the supercharger.

To refit:

1. With the supercharger nose bracket bolted to the engine mounting plinth, fit the upper fixing on the alternator to the nose bracket outer end (with 13.5mm spacer). This defines the position of the nose bracket. Tighten bracket to engine mounting plinth to 50 Nm. Remove alternator top bolt and swing down to allow supercharger to be fitted.
2. Prepare supercharger: Clean mating faces of supercharger and outlet adaptor using Betaclean 3900. Fit 'O' ring into groove in outlet adaptor and fit to supercharger using 6 off M8 x 25 setscrews with Permabond A130. On the fixing located inside the adaptor, Permabond should be applied over the entire thread length. Orientate the adaptor with the outlet pointing towards the rear of the car when fitted. Torque tighten all fixings to 25 Nm.
Clean mating faces of outlet adaptor and outlet elbow using Betaclean 3900. Fit 'O' ring into groove in outlet adaptor face. Fit outlet elbow to point to LH side of car using 4 off M8 x 25 setscrews with a pipe clip bracket secured by both rearmost fixings. Tighten to 25 Nm.
3. Fit M8 stud B111E6081S into RH top (as viewed on face) fixing position in supercharger inlet flange. Clean mating face on supercharger and inlet adaptor using Betaclean 3900. Fit 'O' ring into groove in adaptor face and fit adaptor to supercharger using 2 off M8 x 30 flange head bolts in top positions and M8 flange nut on stud - all 25 Nm. Disregard 4th position at this stage.
4. Mount supercharger: With the pulley removed from the supercharger, slide the nose into the nose bracket until hard against the machined step. Support to the inlet manifold sliding bushes using M10 x 50 flange head bolts and Permabond A130, but do not tighten. Tighten the nose bracket socket head pinch bolt to 25 Nm.
5. Loosley fit the supercharger support strut between the inlet adaptor (M8 x 55 bolt with A130) and the clutch slave cylinder fixings (M8 x 25 with A130). Tighten the three support strut bolts to 25 Nm. Carefully tighten the two M10 x 50 flange head bolts to pull in the two spacers evenly to clamp against the supercharger.
6. Refit the alternator upper bolt and spacer and tighten to 25 Nm. Tighten the lower bolt to 25 Nm.
7. Fit the pulley to the supercharger with the longer boss towards the 'charger. Fit the nut onto the shaft, and use a strap wrench to hold the pulley whilst the nut is tightened to 61 Nm.



8. Use a 6-point socket on the tensioner arm to allow fitment of the multirib accessory drive belt around the pulleys as shown, ensuring that the belt is correctly seated in all the ribbed pulleys.

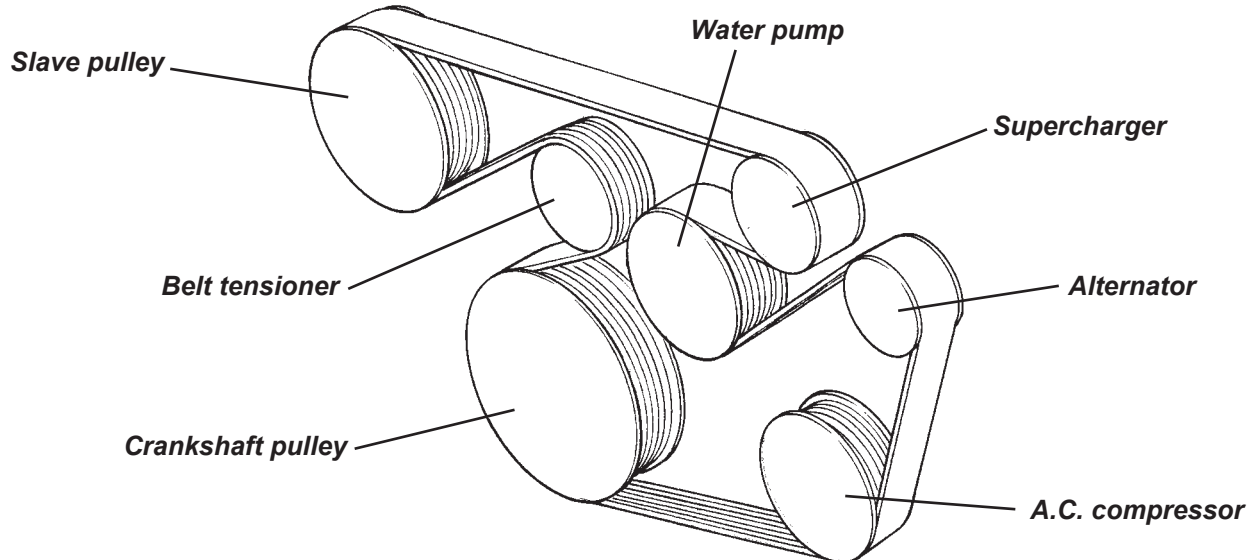

9. Refit other components in reverse order to removal.

Note areas of change compared with standard models;

- # Engine dipstick tube altered to avoid supercharger.
- # Crankcase breather pipe altered to avoid supercharger.
- # Relays on engine bulkhead move to avoid supercharger by-pass capsule
- # Charcoal canister moved from bulkhead to bracket on top of chassis right hand rear upright member to avoid alternator.

EXIGE S/C.G - WHEELS & TYRES

240R cars use lightweight forged alloy 5-spoke roadwheels at 7x16 and 8x17 are ½ inch wider, front and rear, than standard Exige wheels, but retain the standard insets of + 31.3 mm and + 38.0 mm. The wheels are finished in either Satin Black or High Power Silver dependent on body colour (see above). 'Lotus Sport' is moulded into one of the spokes of each wheel. Cup and Exige S models use standard Exige wheels finished in hi-power silver.

The Lotus specific, regular Exige Yokohama A048 tyres, identified by 'LTS', are fitted as standard.

EXIGE S/C.J - BRAKES

For 240R and Cup models, the braking system is updated in the following respects:

- Motorsport brake pads are fitted front and rear;
- Steel braided brake hoses fitted all round;
- Front and rear brake callipers are finished in 'Sport Yellow';
- Hydraulic system filled with Castrol 'SRF' synthetic racing brake fluid. Over 500°F boiling point. Dot 4.

EXIGE S/C.K - COOLING

Twin front mounted oil/air coolers (std. Exige hot climate spec.) are fitted to all supercharged Exige models. An engine intake air chargecooler radiator is rubber mounted to the engine, with cooling airflow collected by the roof duct and directed via the tailgate panel and flexible bellows to the radiator, after which the hot air exhausts through the tailgate louvres.



EXIGE S/C.O - MAINTENANCE & LUBRICATION

A Maintenance Schedule for supercharged cars is available under part number LSL460b.

Recommended lubricants are unchanged apart from:

- 240R & Cup cars: Brake Fluid; Castrol SRF
- Fuel; Unleaded 98 RON

Spark plugs are part number ALS3E6015F (NGK PFR7G) with 0.8mm (- 0.1, + 0) gap.

EXIGE S/C.Q - CLUTCH

240R and Cup cars use an updated clutch cover assembly and a competition specification sintered metal friction plate. No routine maintenance is required other than annual renewal of the Castrol SRF hydraulic fluid.

EXIGE S/C.Z - MISCELLANEOUS

Supercharged models also differ from standard Exige in the following respects:

- # Engine dipstick tube altered to avoid supercharger.
- # Relays on engine bulkhead moved to avoid supercharger by-pass capsule.
- # Charcoal canister moved from bulkhead to bracket on top of chassis right hand rear upright member.